

**UNDERGROUND CUSTOMER ELECTRIC TEMPORARY POLE (CTPL) SPECIFICATIONS**  
 ALL INSTALLATIONS TO MEET REQUIREMENTS OF THE NATIONAL ELECTRIC CODE

- 1) CUSTOMER TO PURCHASE AND INSTALL A TREATED POLE WITH A MINIMUM DIAMETER OF 4 INCHES AT THE GROUND LINE. THE POLE MUST BE EMBEDDED A MINIMUM OF 2 FEET IN GROUND WITH A MINIMUM OF 4 FEET CLEARANCE ABOVE GROUND.
- 2) CUSTOMER TO PURCHASE AND INSTALL METER BASE (MINIMUM 100 AMP), WEATHERPROOF BREAKER PANELS, WEATHERPROOF RECEPTACLES, PER NATIONAL ELECTRIC CODE. REQUIRED MINIMUM 1- 1/4 INCH PVC OR SEALTITE CONDUIT FOR SERVICE ENTRANCE.
- 3) CUSTOMER TO PURCHASE AND INSTALL SERVICE CONDUCTOR WIRES WITH APPROPRIATE UNDERGROUND TYPE (SIZE AND TYPE PER THE NATIONAL ELECTRIC CODE) 5 FEET MINIMUM CABLE PIG TAIL BEYOND CONDUIT FOR HUNTSVILLE UTILITIES TO CONNECT TO THE TRANSFORMER. THE CUSTOMER IS TO MAKE ALL CONNECTIONS IN THE METER BASE. NOTE: ALL MATERIAL WILL BE MOUNTED SECURELY AND MADE WEATHERPROOF FOR SAFETY.

- 4) METER BASE TO BE PLACED 4 TO 5 FEET ABOVE THE GROUND.
- 5) ALL 120 VOLT CIRCUITS REQUIRE GFI BREAKER, OR GFI RECEPTACLE; 240V CIRCUITS DO NOT REQUIRE A GFI. (GFI = GROUND FAULT INTERRUPTER).
- 6) CUSTOMER TO PURCHASE AND INSTALL A 5/8 INCH COPPER CLAD GROUND ROD A MINIMUM OF 8 FEET IN LENGTH WITH 7- 1/2 FEET DRIVEN IN GROUND. GROUND WIRE TO BE CONNECTED FROM GROUND ROD TO BREAKER PANEL.
- 7) CUSTOMER TO OBTAIN A PERMIT, MEET ALL REQUIREMENTS, AND OBTAIN AN INSPECTION RELEASE NUMBER FROM THE APPROPRIATE INSPECTION DISTRICT LISTED BELOW:

- CITY OF HUNTSVILLE (256-427-5336)
- CITY OF MADISON (256-772-5644 OPTION 1)
- TOWN OF TRIANA (256-772-0151)
- MADISON COUNTY INSPECTION (256-746-2950)
- TOWN OF OWENS CROSSROADS (256-725-4163 OPTION 7)

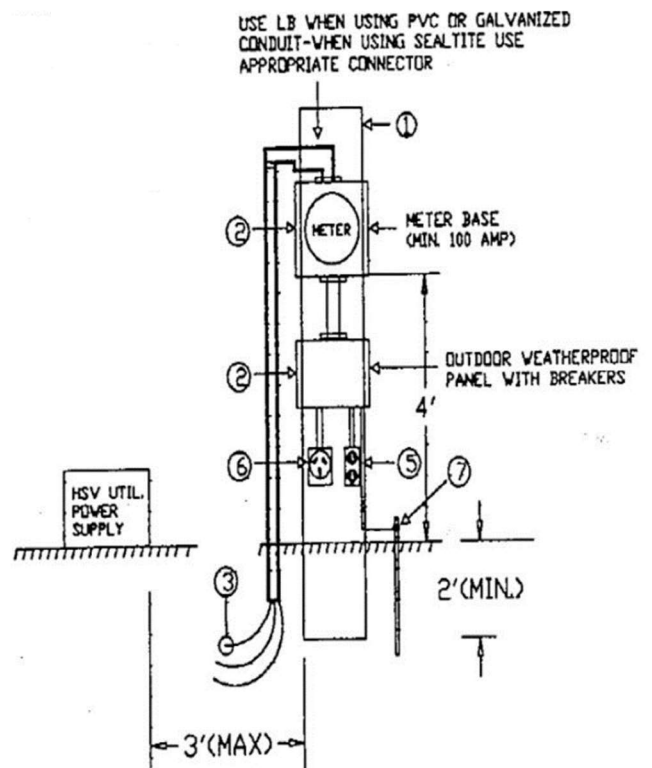

# OVERHEAD CUSTOMER ELECTRIC TEMPORARY POLE (CTPL) SPECIFICATIONS

ALL INSTALLATIONS TO MEET REQUIREMENTS OF THE NATIONAL ELECTRIC CODE

- 1) CUSTOMER TO PURCHASE AND INSTALL A TREATED POLE WITH A MINIMUM DIAMETER OF 6 INCHES AT THE GROUND LINE OR A 4 X 4 WITH ADEQUATE BRACES/GUYS.
- 2) HUNTSVILLE UTILITIES WILL PULL SERVICE TO CUSTOMERS TEMPORARY POLE. THE POLE MUST BE EMBEDDED A MINIMUM OF 3 FEET IN GROUND WITH 10 FEET CLEARANCE ABOVE GROUND WHERE SERVICE IS NOT SUBJECT TO VEHICULAR CLEARANCE, AND 15 FEET CLEARANCE ABOVE GROUND WHERE SUBJECT TO TRAFFIC. TEMP POLES ARE TO BE SET AT A MINIMUM OF 15 FT FROM UTILITY POLE. MAXIMUM DISTANCE 100 FT. FOR A 6INCH POLE OR 75 FT MAX DISTANCE FOR A 4 X 4.
- 3) CUSTOMER TO PURCHASE AND INSTALL A 5/8 INCH GALVANIZED EYEBOLT NEAR TOP OF POLE.
- 4) CUSTOMER TO PURCHASE AND INSTALL WEATHERHEAD.
- 5) CUSTOMER TO PROVIDE AT THE WEATHERHEAD, A MINIMUM OF 18 INCHES OF SERVICE ENTRANCE CABLE FOR MAKING CONNECTION TO HUNTSVILLE UTILITIES SERVICE DROP.
- 6) CUSTOMER TO PURCHASE AND INSTALL EITHER: THREE SINGLE CONDUCTOR CABLE IN PVC OR GALVANIZED; OR SERVICE ENTRANCE CABLE WITH WEATHERPROOF CONNECTIONS AND 'C' CLAMPS. CABLE SHOULD BE INSTALLED FROM METER BASE MAIN DISCONNECT. (WIRE SIZE AS PER NATIONAL ELECTRIC CODE).
- 7) CUSTOMER TO PURCHASE AND INSTALL METER BASE (MINIMUM 100 AMP), WEATHERPROOF BREAKER PANELS, WEATHERPROOF RECEPTACLES, PER NATIONAL ELECTRIC CODE.
- 8) METER BASE TO BE PLACED 4 TO 5 FEET ABOVE THE GROUND.
- 9) ALL 120 VOLT CIRCUITS REQUIRE GFI BREAKER, OR GFI RECEPTACLE; 240V CIRCUITS DO NOT REQUIRE A GFI. (GFI = GROUND FAULT INTERRUPTER).
- 10) CUSTOMER TO PURCHASE AND INSTALL A 5/8 INCH COPPER CLAD GROUND ROD A MINIMUM OF 8 FEET IN LENGTH WITH 7- 1/2 FEET DRIVEN IN GROUND. GROUND WIRE TO BE CONNECTED FROM GROUND ROD TO BREAKER PANEL.
- 1) CUSTOMER TO OBTAIN A PERMIT, MEET ALL REQUIREMENTS, AND OBTAIN AN INSPECTION RELEASE NUMBER FROM THE APPROPRIATE INSPECTION DISTRICT LISTED BELOW:
  - CITY OF HUNTSVILLE (256-427-5336)
  - CITY OF MADISON (256-772-5644 OPTION 1)
  - TOWN OF TRIANA (256-772-0151)
  - MADISON COUNTY INSPECTION (256-746-2950)
  - TOWN OF OWENS CROSSROADS (256-725-4163 OPTION 7)

